

SH A High-Capacity Rubber Roll Sheller



Shelling Machinery

SH A

High-Capacity Rubber Roll Sheller

During entering the machine the paddy passes a photo cell.

The photo cell activates the following vibratory feeder as well as the previously adjusted pressure of the rubber rolls. The paddy enters via a new designed chute the shelling gap between the rubber rolls which are mounted diagonal.

A fan for intensive cooling of the rubber rolls ensures a long service life of the rolls which helps to achieve lowest operating costs.

The sheller should preferably be connected to an aspiration system.

The mixture of shelled rice, paddy and husk leaves the rubber roll sheller through the outlet to the husk separator.

Usually, the rubber roll sheller is combined with the closed circuit husk separator HUS 1260 and will be delivered as one unit.

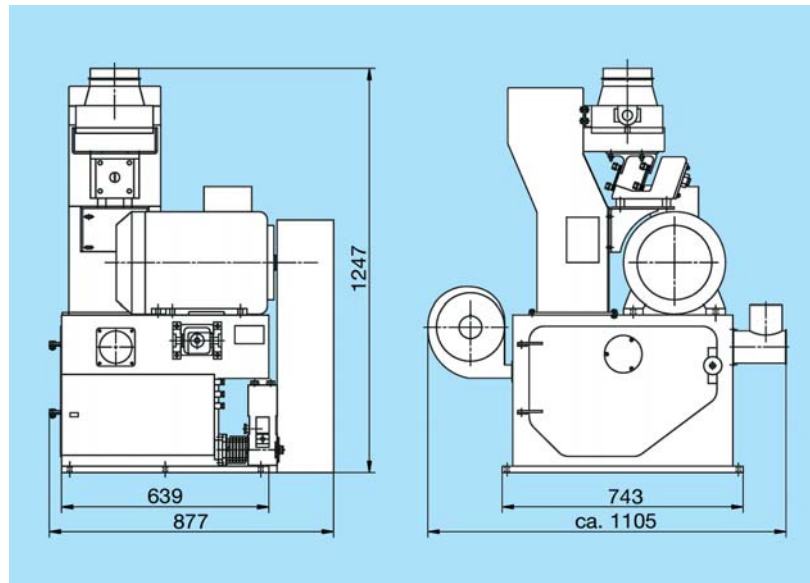

Dimensions of the High-Capacity Rubber Roll Sheller SH A

Technical Data SH A

Capacity per hour*	Motor Power		Air required	
	Sheller	Blower	Aspiration	Compressor 10 Bar
Kilos	kW	kW	m ³ /min	ltr./min
Up to 6,000	up to 11.0	0.2	8	30

* Depending on product

Shipping Data

Net weight	Gross weight	Cubage
Kilos	Kilos	m ³
~700	~850	1.2

We reserve the right to deviate from illustrations and data as improvements are constantly being made.