

VERTICONE VPC 320 (patented)

Conical Shelling Machine for Cereals and Beans



Vertical shelling from top to bottom. The Verticone VPC operates with abrasive conical discs with air-feed openings in between. The small diameter of the conical shelling rotor is placed at the top, right underneath feeding section while the big diameter is placed at the bottom, before the outlet section.

The product is conveyed to the machine by a vertical feeding pipeline. A conical distributor within the round inlet bin divides the product uniformly to the feeding worm which feeds the product into the shelling chamber.

The counterpressure disc which is adjustable connected by three springs in the outlet section causes a uniform filling ratio and uniform pressure within the entire working chamber.

This ensures a gentle and uniform shelling of the product. Air cools the product during the shelling procedure and supports the discharge of the husk. The husk is removed by a separate aspiration system.

The shelling degree is influenced by the following parameters:

- Throughput capacity per hour
- Gap adjustment between stones and sieves
- Position of the brakes
- Counterpressure disc

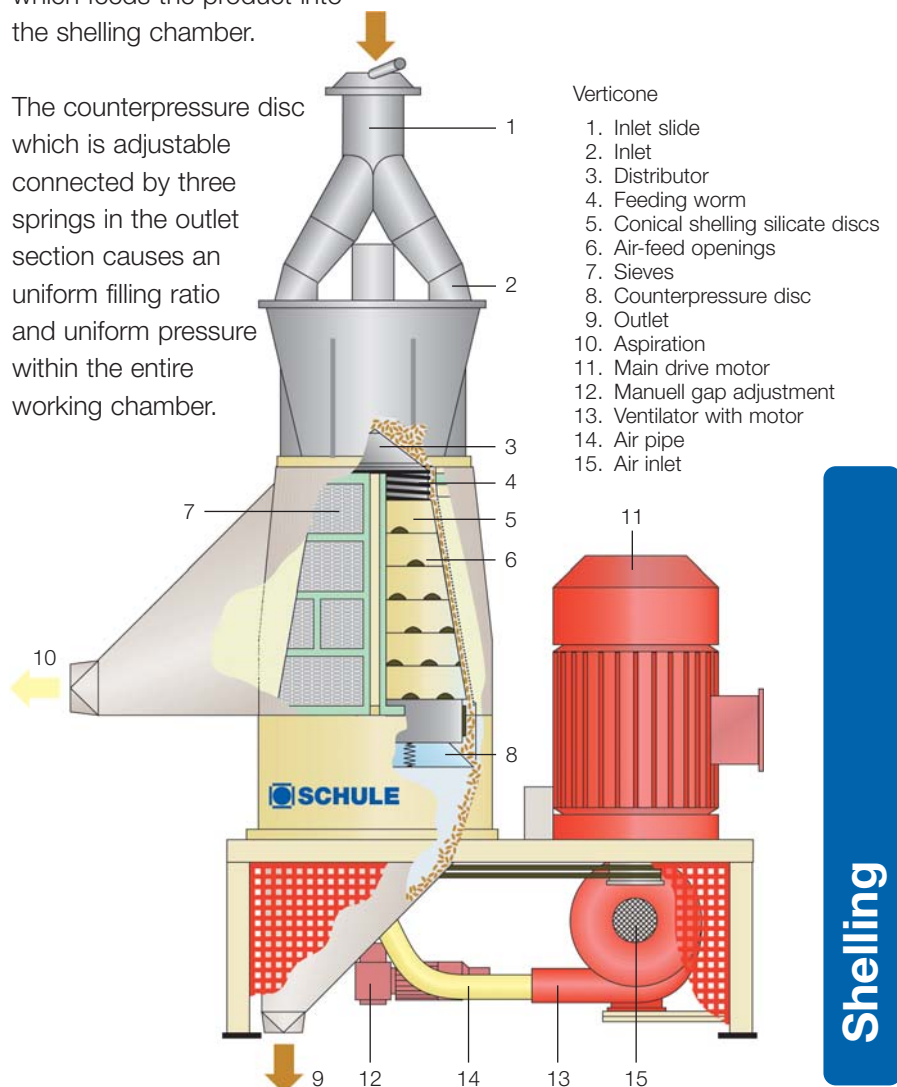

Shelling

Verticone VPC 320 (patented)

Conical sheller for gentle milling of cereals and beans

- New conical milling concept
- Abrasive silicate discs
- Diameter of discs 225 - 330 mm
- Low speed on top for gentle starting
- Variable gap-setting enabled by adjusting the height of the shelling rotor
- New outlet design to avoid high pressure to the cereals



Sieve



Shelling rotor

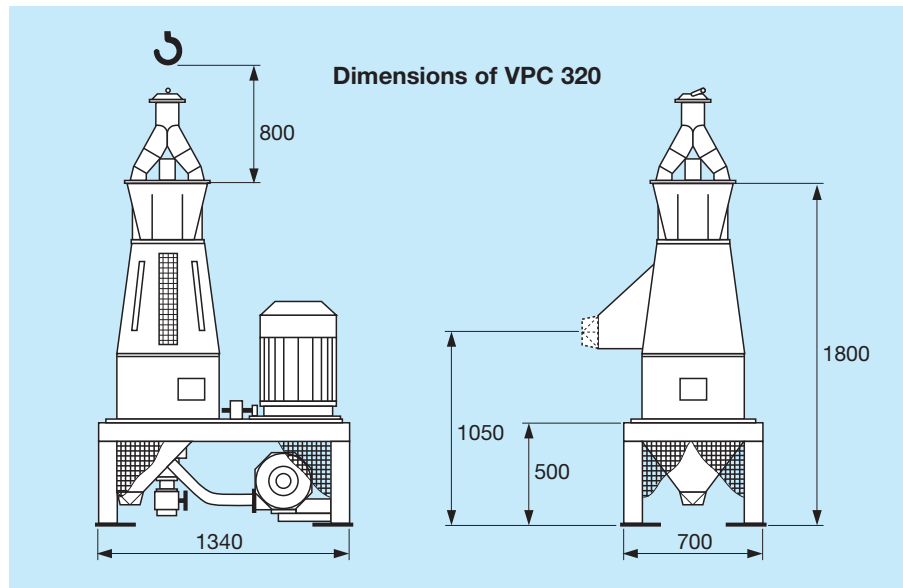

The capacity depends on required shelling degree, number of passes, and quality/uniformity of product.

Technical Data

Capacity Reference			Motor Capacity		Air Capacity of Ventilator		Required aspiration		Net Weight	Gross Weight	Volume
Wheat	Barley	Soy-beans	Main Drive	Ventilator	m ³ /min	daPa WC	m ³ /min	daPa WS	kg	kg	m ³
up to 3.0	up to 5.0	up to 3.0	37	1,1	10.5	500	30-40	150	1160	1500	5.0

We reserve the right to deviate from illustrations and data as improvements are constantly being made.



F. H. SCHULE Mühlenbau GmbH

Dieselstraße 5-9
D - 21465 Reinbek / Hamburg
Phone: +49 (0)40 7 27 71 - 700
Fax: +49 (0)40 7 27 71 - 710

schule@amandus-kahl-group.de

www.schulefood.de

