

## Gravity Selector LKA

for elimination of light and heavy particles

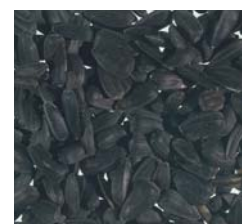

# Gravity Selector LKA

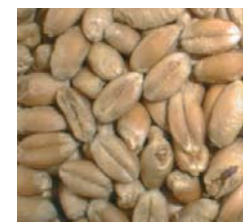
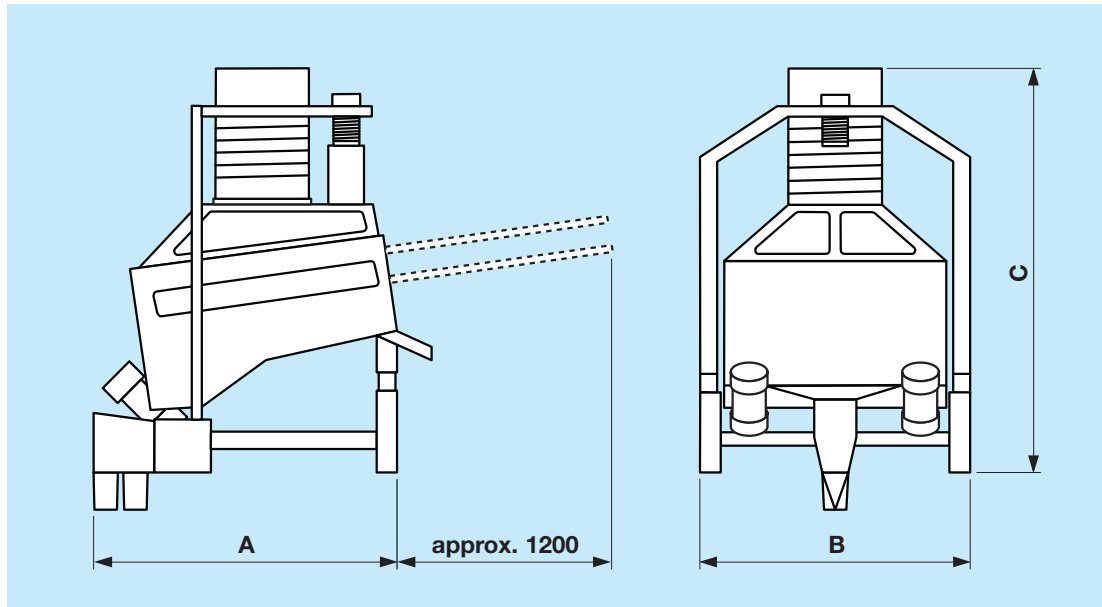

Type	Capacity Paddy (t/h)	Heavy grain (t/h)	Motors (kW)	Aspiration (m <sup>3</sup> /h)	Weight netto (kg)	Volumen (m <sup>3</sup> )	Dimensions		
							A (mm)	B (mm)	C (mm)
LKA 1	6	8	2 x 0.35	5400	350	4.2	1630	1058	2170
LKA 2	14	18	2 x 0.68	9000	450	5.6	1630	1450	2170
LKA 3	19	25	2 x 0.68	14400	700	8.2	1650	2000	2180